

Monitor for continuous measurement of pH or redox (ORP) in high purity water, steam and condensate.

Monitor AMI pH/Redox QV-Flow

Complete system mounted on stainless steel panel:

- **Transmitter AMI pH/Redox** in a rugged aluminum enclosure (IP 66).
- Various combined or separated sensors with reference electrodes available.
- **Flow cell QV-Flow IS1000** made of stainless steel with quick release vessel, needle valve, digital sample flow meter and temperature sensor.
- Factory tested, ready for installation and operation.

Specifications:

- Measuring range:
1 to 13 pH respectively -500 to +1500 mV depending on installed sensor.
- Simultaneous measurement of pH or redox, sample temperature and sample flow.
- Big backlit LC display for the reading of measuring value, sample temperature, sample flow and operating status.
- Easy user menus with simple programming of all parameters by keypad.
- Two current outputs (0/4 - 20 mA) for measured signals (3rd output optional).

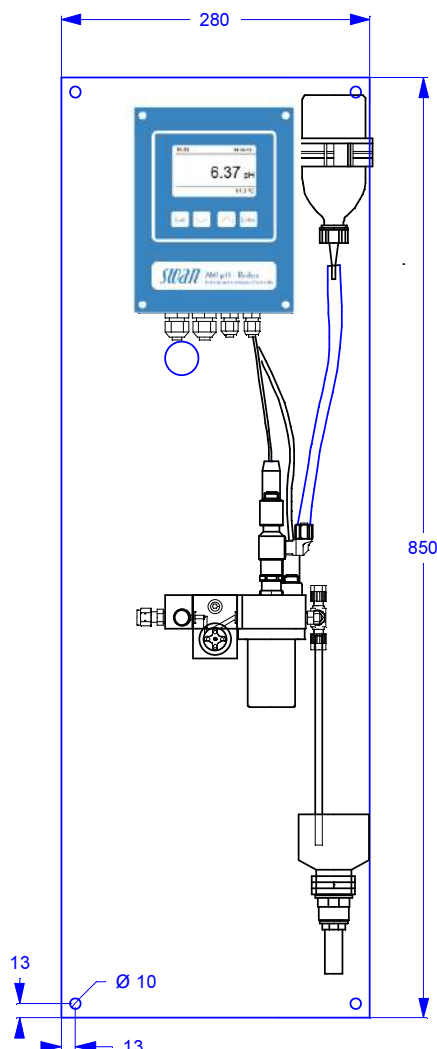

Order Nr.	Monitor AMI pH/Redox QV-Flow AC	A-21.211.010
	Monitor AMI pH/Redox QV-Flow DC	A-21.212.010
Option:	[] 3 rd current signal output (0/4 – 20mA)	A-81.420.050
	[] Profibus DP & Modbus RTU interface (RS-485)	A-81.420.020
	[] USB interface	A-81.420.042
	[] HART interface	A-81.420.060
Option:	[] Swansensor pH Standard (requires Adapter A-83.910.120)	A-87.120.200
	[] Swansensor pH SI	A-87.110.200
	[] Swansensor pH FL (requires SS Reference FL)	A-87.150.200
	[] Swansensor ORP Standard (requires Adapter A-83.910.120)	A-87.420.200
	[] Swansensor ORP SI	A-87.410.200
	[] Swansensor ORP FL (requires SS Reference FL)	A-87.411.200
Option:	[] Swansensor Reference FL (requires cable A-88.121.120)	A-87.860.100

pH/ORP Measurement

Signal input galvanically separated
Input resistance: > 10¹³ Ω

pH measurement

Measuring range with:
-Swansensor ST/AY: pH 1 to 13
-Swansensor SI/FL: pH 1 to 12
Resolution: 0.01 pH
Reference temperature: 25 °C

ORP measurement

Measuring range with:
-Swansensor ST/AY: -400 to 1200 mV
-Swansensor SI/FL: -500 to 1500 mV
Resolution: 1 mV

Temperature compensations

automatic, according to:
- Nernst (for potable water and wastewater)
- Nernst with non-linear solution compensation (for high purity water)
- Nernst with linear compensation with selectable coefficient (for high purity water)

Calibration solutions table

Programmable table for pH buffers and ORP calibration solution.

Temperature measurement Pt1000

Measuring range: -30 to +130 °C
Resolution: 0.1 °C

Transmitter Specifications and Functionality

Electronics case: Cast aluminum
Protection degree: IP 66 / NEMA 4X
Display: backlit LCD, 75 x 45 mm
Electrical connectors: screw clamps
Dimensions: 180 x 140 x 70 mm
Weight: 1.5 kg
Ambient temperature: -10 to +50 °C
Humidity: 10 - 90% rel., non condensing

Power supply

Voltage:
AC version: 100 - 240 VAC (± 10 %),
50/60 Hz (± 5 %)
DC version: 10-36 VDC
Power consumption: max. 35 VA

Operation

Easy operation based on separate menus for "Messages", "Diagnostics", "Maintenance", "Operation" and "Installation".

User menus in English, German, French and Spanish.

Separate menu specific password protection.

Display of process value, sample flow, alarm status and time during operation.
Storage of event log, alarm log and calibration history.

Storage of the last 1'500 data records in logger with selectable time interval.

Electrical Connection Scheme

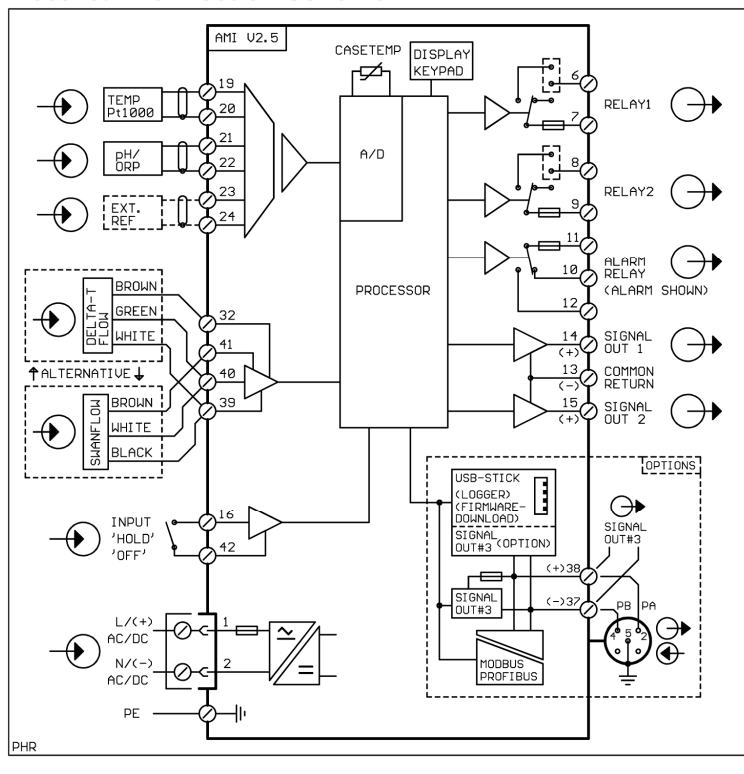

Safety features

No data loss after power failure, all data is saved in non-volatile memory.
Overvoltage protection of in- and outputs.
Galvanic separation of measuring inputs and signal outputs.

Transmitter temperature monitoring
with programmable high/low alarm limits.

1 Alarm relay

One potential free contact for summary alarm indication for programmable alarm values and instrument faults.
Maximum load: 1A / 250 VAC

1 Input

One input for potential-free contact.
Programmable hold or remote off function.

2 Relay outputs

Two potential-free contacts programmable as limit switches for measuring values, controllers or timer for system cleaning with automatic hold function.
Rated load: 1A / 250 VAC

2 Signal outputs (3rd as option)

Two programmable signal outputs for measured values (freely scalable, linear or bilinear) or as continuous control output (control parameters programmable) as current source. 3rd signal output selectable as current source or current sink.
Current loop: 0/4 - 20 mA
Maximum burden: 510 Ω

Control functions

Relays or current outputs programmable for 1 or 2 pulse dosing pumps, solenoid valves or for one motor valve. Programmable P, PI, PID or PD control parameters.

1 Communication interface (option)

- RS485 interface (galvanically separated) with Fieldbus protocol Modbus RTU or Profibus DP
- 3rd Signal output
- USB interface
- HART interface

Monitor Data

Sample conditions

Flow rate: 5 to 10 l/h
Temperature: up to 50 °C
Inlet pressure: 0.2 to 2 bar
Outlet pressure: pressure free

Flow cell and connections

Flow cell made of stainless steel with quick release vessel with built-in flow adjustment valve, digital sample flow meter and Pt1000 temperature sensor.
Sample inlet: Swagelok 1/4" tube adapter
Sample outlet: G 1/2" adapter for flexible tube Ø 20 x 15 mm

Panel

Dimensions: 280 x 850 x 150 mm
Material: stainless steel
Total weight: 8.0 kg

Viet Nam Market Leader in

**ENVIRONMENTAL MONITORING
& INDUSTRIAL MEASUREMENT SOLUTIONS**



Headquarters

4E Street 6, An Phu Ward, Thu Duc City,
Ho Chi Minh City
Hotline: (+84) 901 379 116



Ha Tinh Office

Lien Phu Hamlet, Ky Lien Ward,
Ky Anh Town, Ha Tinh Province
Hotline: (+84) 938 442 414

Northern Viet An

Lot 33, BT4-1 residential area, Trung Van ward,
Nam Tu Liem district, Hanoi
Hotline: (+84) 901 851 116



Eurowater Technology

9A Street 6, An Phu Ward,
Thu Duc City, Ho Chi Minh City
Hotline: (+84) 909 788 959

Viet An Central

5A Mai Xuan Thuong Street, Hoa Khe Ward,
Thanh Khe District, Da Nang City
Hotline: (+84) 898 119 116



iLotusLand Viet Nam

9A Street 6, An Phu Ward,
Thu Duc City, Ho Chi Minh City
Hotline: (+84) 90 940 3778

